

Nursery Home Learning

Week beginning: 06/07/2020

Our topic this half term is Seaside Holidays

Phonics: Letter search

The Lighthouse Keeper's Lunch

Monday

Story of the week...

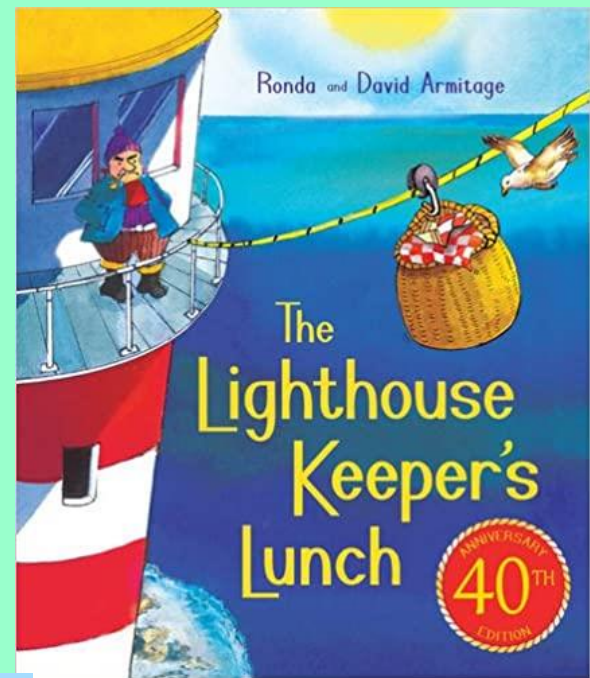

<https://www.youtube.com/watch?v=46wCRq50Wwg>

Steps to success:

- Listen to the Jolly Phonics song: (<https://www.youtube.com/watch?v=1Qpn2839Kro>)
- Listen to the story The Lighthouse Keepers Lunch By Ronda and David Armitage.
- Can you retell the story?
- What sounds can you hear and see in the story?
- Practice your letter formation.
- Can you remember how to hold your pencil?

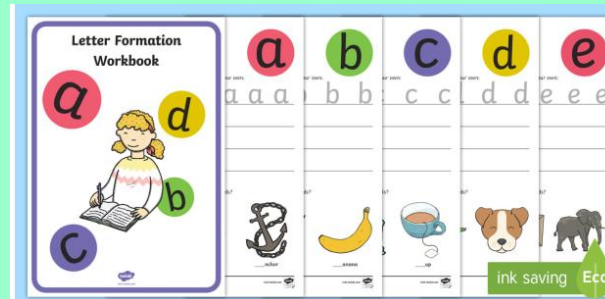

Letter formation

<https://www.twinkl.co.uk/resource/t-l-068-letter-formation-workbook>

Pencil grip

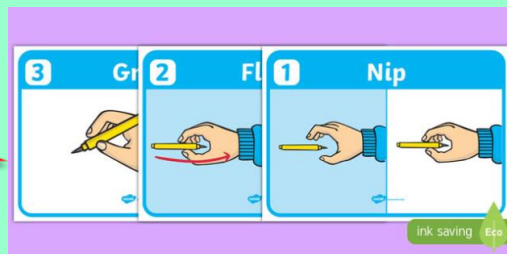

<https://www.twinkl.co.uk/resource/t-m-745-how-to-grip-a-pencil-poster-nip-flip-grip>

Maths: 2D shapes

Learning objective:

Make shape sandwiches.

Recognise numerals on the list.

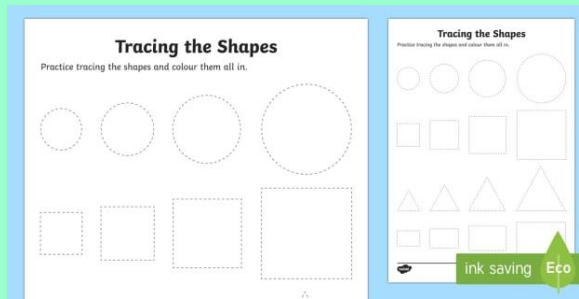

Practice drawing your 2D shapes.

<https://www.twinkl.co.uk/resource/t-n-1293-basic-shape-tracing-worksheet>

Steps to success;

- Recap 2D shapes.
- Draw 2D shapes.
- Make lunch like Mrs Grinling did in the story.
- Cut your sandwiches into different shapes.
- Read the list to pack a picnic using your numbers and sounds.

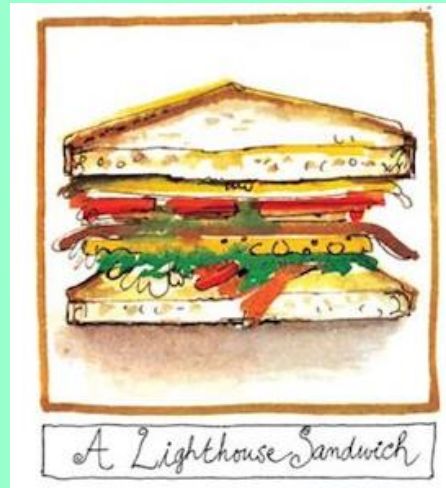
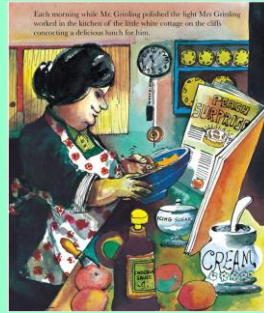

Can you read the list to pack a picnic:



Enjoy your picnic outside with your family.

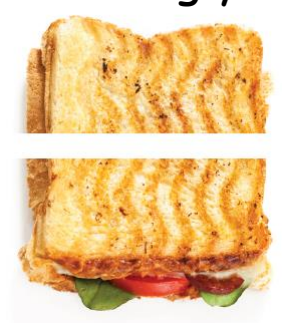

Creative:

Blind fold food tasting.

Learning objective: Use your senses to help you identify the different food.

Steps to success;

- Use different senses to identify food.
- Describe how the food smells, feels and tastes.
- You can ask questions about the food.
- Try new food.
- Rate the food you tried.
- Learn where the food has come from.

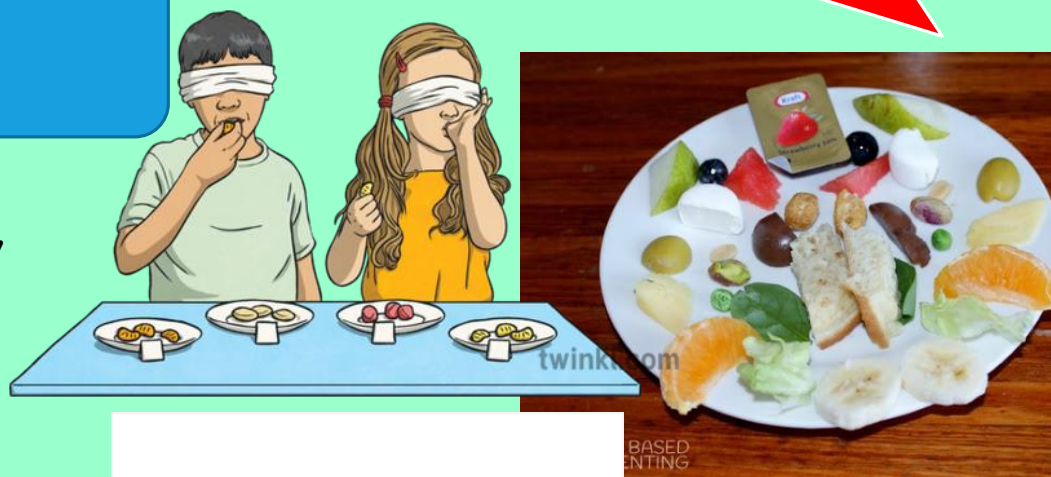

It smells like....

It tastes like....

It feels like....



Crunchy Carrots:
from farm to fork



Farm to Fork
Online Field Trips



Did you like the food?



<https://www.twinkl.co.uk/search?term=food+tasting>

Where has the food come from?

<https://www.youtube.com/watch?v=Pf74rrn1uLk&list=PLPByZBLrw9YppZLq10PvAOYEV3RIuK33H&index=3&t=0s>

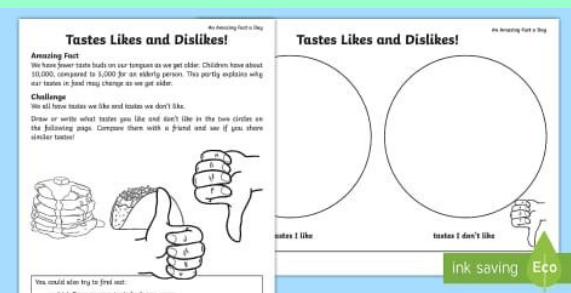

Tuesday

Phonics: All about the initial sounds.

Learning objective:
Hear and match the pictures with the sounds.

Steps to success:

- Identify different sounds.
- Can you hear the initial sound?
- Match the picture with the correct sound.
- You can draw the pictures and label them with the correct sound.
- Try writing a CVC word.



Can you sound out the word.



b s c f t l b s n r

Maths: Race a paper aeroplane.

Learning objective:

Make a paper aeroplane and have a race looking at the number it landed in.



Steps to success:

- Using your fine motor skills fold card or paper to make paper aeroplanes with your family.
- Label your aeroplanes with your age. e.g. if you are four write 4 on your aeroplane.
- Create a large number line. This can be done outside with chalk or on pieces of paper.
- To make it fair make sure everyone stands at the start of your number line.
- Count 1,2,3, and on 3 everyone throws their aeroplanes.
- What number did yours land on?
- Whose flew the furthest?
- Who came 1st 2nd and 3rd?

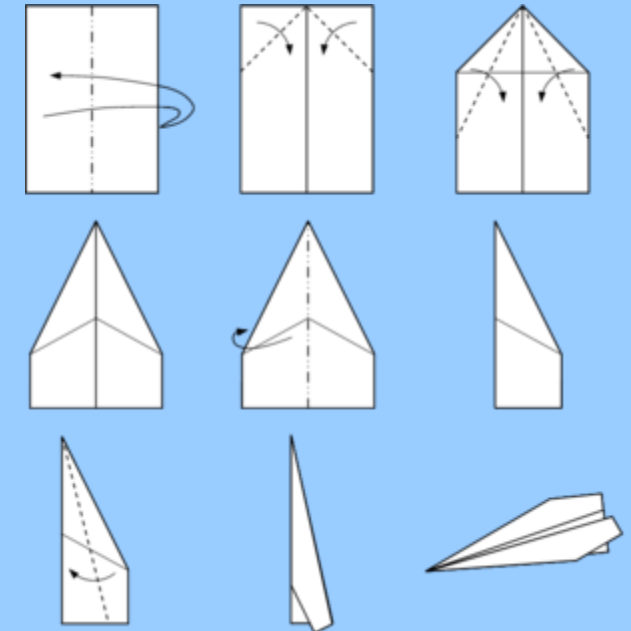
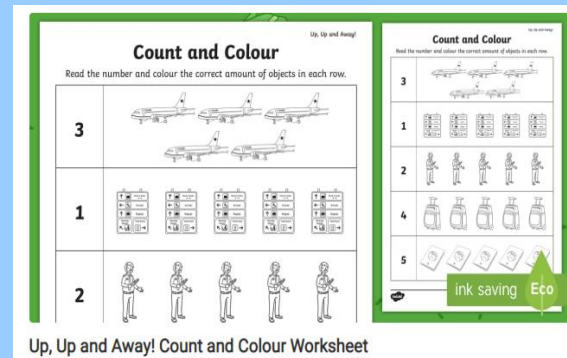

<https://www.twinkl.co.uk/resource/roi-n-5434-up-up-and-away-count-and-colour-activity-sheet>

Creative: Using books and a computer to find out information.

Learning objective: There are more than 60 lighthouses in the UK, use google earth to find some of them.

Steps to success:

- Study maps to find different light houses (google earth, paper map)
- Look up the word lighthouse in the dictionary.
- Ask questions about light houses.
- Use books and the internet to find out the answers.

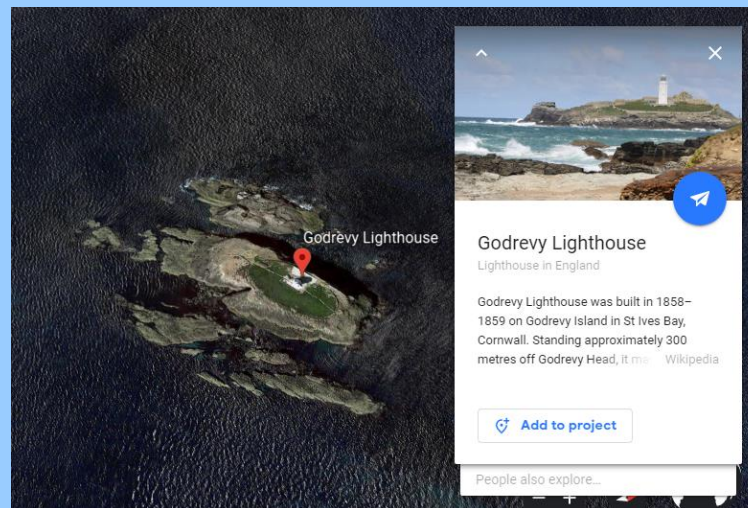

How do light houses work?

<https://www.youtube.com/watch?v=ObyGznyf7BI>

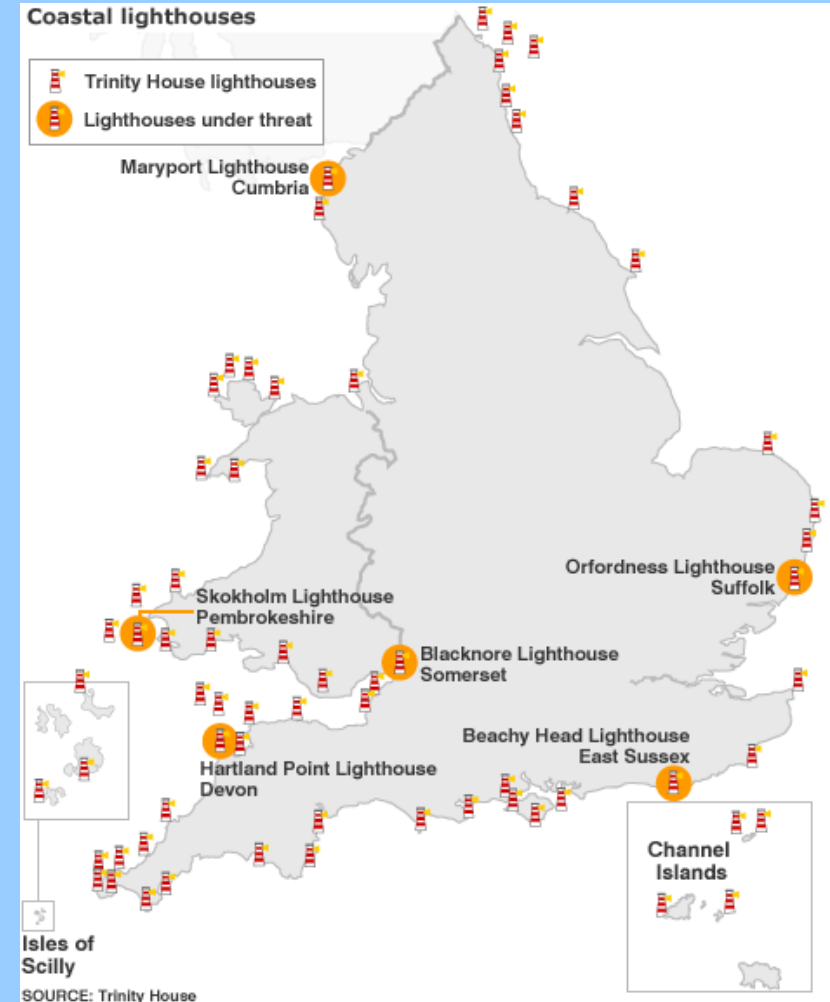

Wednesday

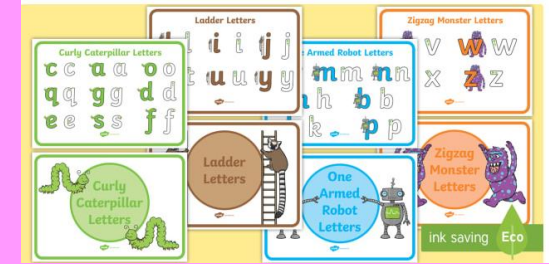

Practice letter formation

<https://www.twinkl.co.uk/resource/t-l-8914-letter-formation-families-display-posters>



Find your capital letter



Phonics: All about your name
Learning objective:
Recognise the capital letter of your name.

Steps to success:

- Look at the jolly phonics capital letters.
- What capital letter does your name begin with?
- Find your capital letter in alphabet spaghetti, Nesquik or anywhere around the house.
- Write your name with spaghetti or noodles.

| The Jolly Phonics Alphabet | | | | | |
|----------------------------|----------------|----------------|----------------|----------------|----------------|
| A to Z | | | | | |
| A a | B b | C c | D d | E e | F f |
| G g | H h | I i | J j | K k | L l |
| M m | N n | O o | P p | Q q | R r |
| S s | T t | U u | V v | W w | X x |
| Y y | Z z | | | | |

Write your name



<https://www.twinkl.co.uk/resource/t-t-2548502-editable-name-recognition-make-read-write-activity-mat>

Maths: Exercise challenge

Learning objective:
Count the amount of exercises you can do in 10 seconds.

Steps to success:

- Put your hand on your chest. Can you feel your heartbeat?
- With a stopwatch or timer how many exercises can you do in ten seconds.
- You can record your number on some paper.

How many:

- Star jumps or jumps
- Hops
- Toe touches
- Squats
- Feel your heart beat now.
- Compare your results.
- What exercise did you do the most of?
- You can challenge yourself to do it for 20 seconds.



Star jumps



Hops



Toe touches



Squats

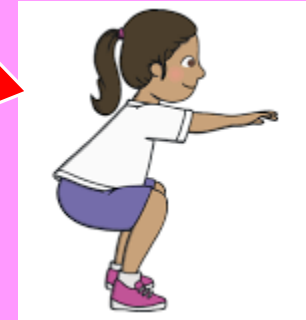

<https://www.twinkl.co.uk/resource/t-m-501--pe-physical-action-cards>

Creative: Make a basket.

Learning objective: Using your fine motor skills make a basket.

Steps to success:

- Use one handed tools and equipment.
- Decorate your basket.
- Test to see if your basket works.



<https://www.twinkl.co.uk/resource/t-t-21500-a-picnic-lunch-eyfs-adult-input-plan-and-resource-pack>



Weave a basket

Use these templates to help make your basket.

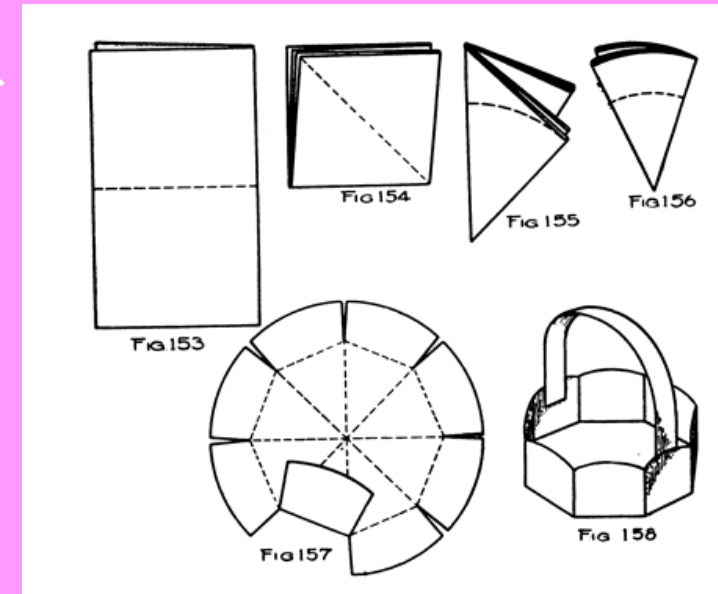
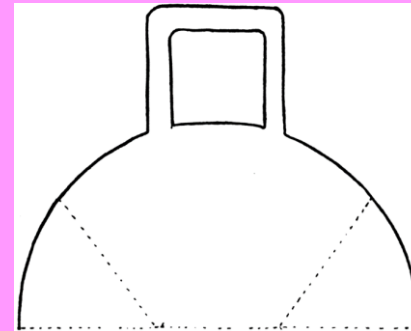

Thursday

Phonics: All about the letters in your name.

Learning objective:
Identify and recognise sounds and letters.

Steps to success:

- Write your name on a strip of paper.
- Cut up your name to separate the letters/sounds.
- Look at your name a letter/sound at a time and search for items around your house beginning with these sounds.
- Place all your item into a pile or box.
- Next sort the items by sound using bowls or baskets.



S a m → S a m

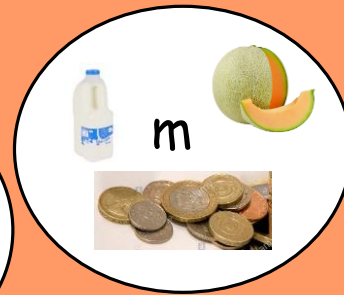
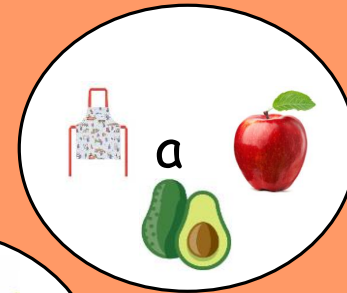

Maths: Sing the number song Ten Green Bottles.

Learning objective: To understand one less.



<https://www.twinkl.co.uk/resources/maths-songs-song-and-rhymes-communication-and-language-and-literacy-early-years/early-years-nursery-rhyme-number-rhymes/early-years-ten-green-bottles>

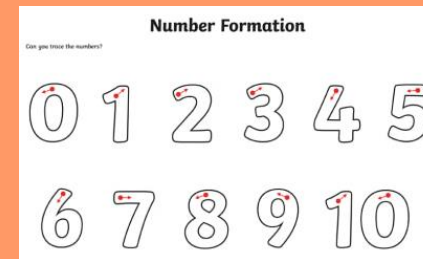

<https://www.youtube.com/watch?v=T0ooQv7oHvw>

- Steps to success:
- Recycle ten bottles.
- Fill the bottles with water half way (you can add a drop of green paint or food colouring to turn the water green).
- Label the bottles with numbers 1-10. You can use your number formation mat to help you.
- Go outside and line the bottles on a wall (you can also use a table).
- Order your bottle numbers 1-10.
- Using a ball or a bean bag can you throw it at a bottle to try and make it fall (try and aim for the number 10) .
- When one has fallen down, you have one less. How many bottles do you have now?
- Repeat game until all the bottles have fallen down.

Creative: Make Iced Sea Biscuits.

Learning objective: Make short bread and decorate with icing to make iced sea biscuits.



<https://www.bbcgoodfood.com/recipes/shortbread-biscuits>

Ingredients

150g plain flour



100g butter



50g castor sugar



Steps to success:

1) Ask an adult to put the oven on 170C/150C fan/gas 3.



2) Wash your hands. Why do you need to wash your hands?



3) Measure the ingredients using scales. Do you recognise any numbers?



4) Put all ingredients into a bowl and use your hands to mix until it looks like breadcrumbs then squeeze until it comes together as dough. What does it feel like? 

5) On a floured surface roll the dough using a rolling pin. How has it changed?



6) Cut biscuits using a cutter. What shape are they?



7) Ask an adult to put them in the oven for 15-20 minutes until golden brown. Talk about safety.



8) Once completely cool decorate with icing sugar.



Phonics: Writing sounds.

Learning objective: Make a diary of your week using pictures and initial sounds.

Steps to success:

- Listen to the story The Lighthouse Keepers Lunch.
- Talk about what happened each day of the week.
- Make a diary about what you have done each day (you can make a book or fold a piece of paper).
- Draw a picture of what you did each day and try and write the sound/letter.

The days of the week song;







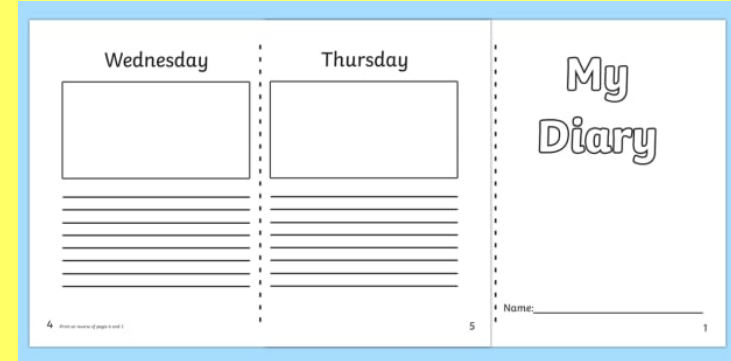



Monday, Tuesday, Wednesday, Thursday, Friday, Saturday, Sunday too. 1 2 3 4 5 6 7 days. Each day different and each day new.

Friday

<https://www.twinkl.co.uk/resource/diary-template-ks1-t-1-891>



The Lighthouse Keepers Lunch by Rhonda and David Armitage - My Storyboard

| | | |
|---|--|--|
|  |  |  |
| On Monday | On Tuesday | On Wednesday |
|  story book |  shape sandwiches |  basket |
|  |  | |
| On Thursday | On Friday | On Saturday |
|  cooking biscuits |  walk in woods | |

Diary ideas



Did you enjoy this weeks story?

If you did you might want to read more stories by Ronda and David Armitage.

Maths: Ordering a number line.

Learning objective:

Make a lighthouse number line by ordering numbers.

Steps to success:

- Make a lighthouse number line using blocks, Lego, Duplo or junk modelling.
- Can you order numbers 1-10?
- Do you recognise numbers?

Draw a picture
With:

1 light house

2 crabs

3 fish

4 shells

5 seagulls



Lighthouse
number line

<https://www.twinkl.co.uk/resource/t-t-2547233-number-lighthouse-to-20-connecting-bricks-game>

Shell hunt
colouring

<https://www.twinkl.co.uk/resource/t-t-22725-seaside-shell-hunt-large-colouring-sheet>



Creative: Make a seagull.

Learning objective: Use different materials and one handed equipment to construct with a purpose in mind.

Steps to success:

- Talk about how you are going to make your seagull and what you will need.
- Draw your seagull's head using a pencil.
- Using scissors cut along where you have drawn.
- Bend the wings forward.
- Decorate your seagull.

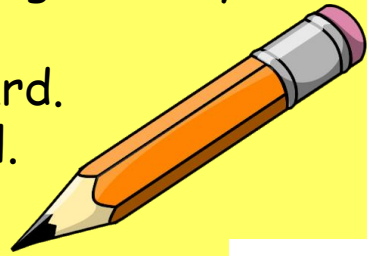

What you will need;

- Paper plate
- Pencil
- Scissors
- Paint, coloured pens or card.

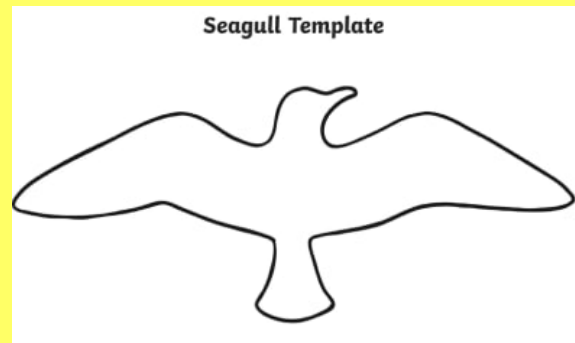
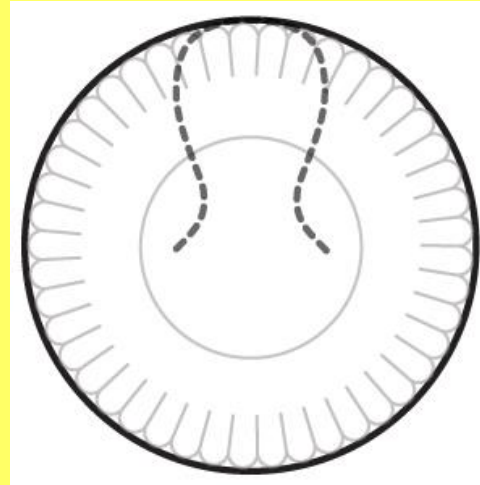

<https://www.twinkl.co.uk/resource/t-t-2547859-seagull-template-activity-sheet>